

ISU® 60.5 2-DOOR

Internal Airlift/ Helicopter Slingable Container Unit (ISU®)

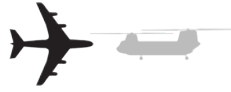

ISU® 60.5 2-DOOR

One example of an ISU® container configuration (ISU®s can be customized to meet your specifications)

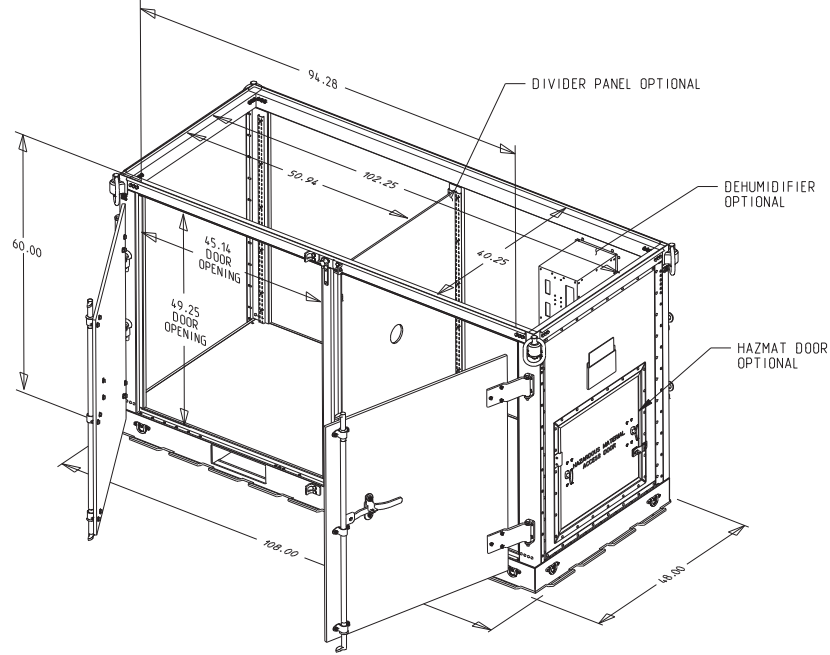

P/N	NSN	COLOR	GSA	DLA
*56112-000	8145-01-316-3292	GREEN	•	
*56212-000		TAN	•	
*56312-000		BLACK	•	
DIMENSIONS				
EXTERIOR	108"W X 48"L X 60"H			
INTERIOR	132 cu.ft.			
WEIGHT	PAYLOAD CAPACITY	MAXIMUM GROSS WEIGHT		
835 lbs.	5,000 lbs.	5,835 lbs.		



*Above part numbers are for containers only; no accessories



ISU® 60.5 transported by helicopter sling

FEATURES

- Two doors, both on one 108" side
- Compatible with U.S. Air Force 48" Center Rail
- 2-way forkliftable
- Intermodal - transportable by air, land, sea or rail
- Stackable two-high when loaded up to 5,000 lbs. payload or empty
- Compatible with standard military transport vehicles/equipment 2.5-ton and 5-ton - FMTV, LMTV, HEMTT, Flatrack, CROP, etc.
- Base pre-drilled for optional caster set
- All aluminum extruded, mechanically fastened pallet base certified not to damage aircraft roller systems
- Winching rings located at every lower corner
- Retractable folding steps for easy roof access for sling hookup

- See Military Certifications starting on page 2.1.4
- See Optional Kits starting on page 2.5.1
- See Optional Accessories starting on page 2.6.1

For more information or for a single part number for a customized ISU® Container, call 800-355-2015